

## INSTRUCTION MANUAL - ENGLISH

### Air Auto Shut-Off Pistol Screwdriver

This product is designed for installing and removing threaded fasteners in wood, metal and plastic. The use of spare parts/ accessories other than those originally supplied by the manufacturer may result in a drop in performance and/or increased maintenance / noise level / vibrations. As a result, the full cancellation of the manufacturer's liability. No other use is permitted. Professional use only.

#### Air Supply Requirements

1. Supply tool with 6.35 KG/CM<sup>2</sup> (90 PSI) clean and dry air. Too much pressure drastically reduces the tool life.
2. Connect the tool to air line using pipe, hose and fitting sizes shown in the diagram below.

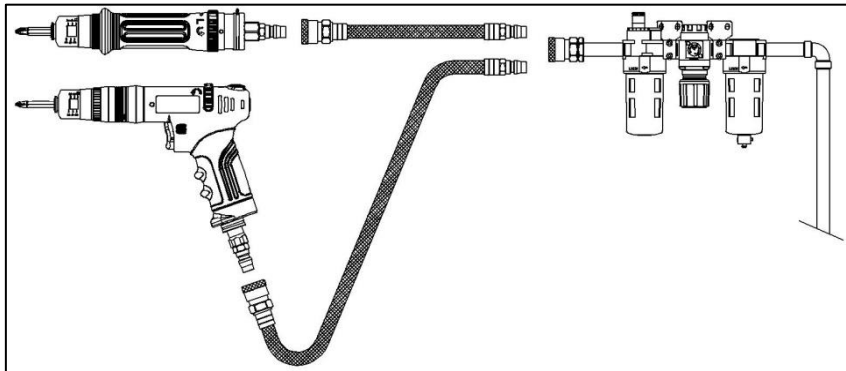

#### Lubrication

1. Use an air line lubricator with SAE #10 oil. Adjusted to two (2) drops per minute. If an air line lubricator is not available, add air motor oil to the inlet once a day.
2. For gearing and clutch, use Shell-grade grease containing molybdenum.
3. Grease clutches every 12,000 screws.

#### Torque Adjustment

**Shut Off Clutch:** Grip the tool around the handle and press the tool into the fixing which is to be tightened. The motor will start and tighten the fixing to the required torque set by adjusting the tension on the clutch spring. At this point, the internal drive is disengaged and the air to the motor cut off.

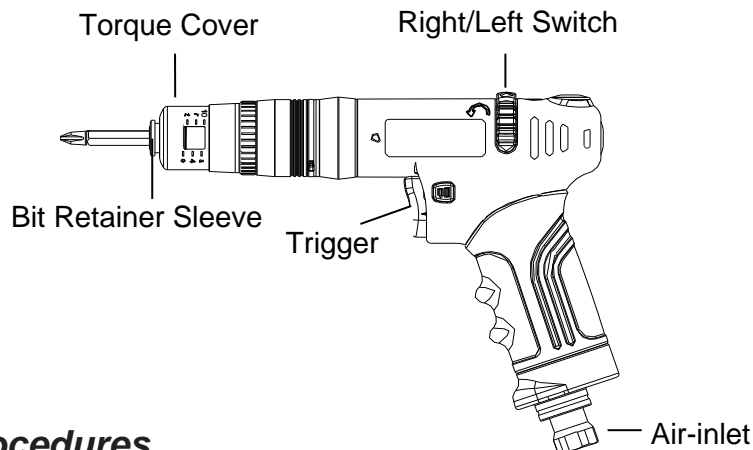

#### Operating Procedures

1. Make sure the air in air line is clean and dry.
2. There are three air-inlets on the tool. Depending on different usage, choose one inlet to connect correctly with the air compressor. Screw up the other two air-inlets separately with screw caps.
3. Install a bit (as illustrated below). Before using, do check the bit being installed on the tool correctly.
4. Torque Adjustment: Take off the torque cover and turn the torque adjustment ring right (clockwise) to increase the torque. Turn the torque adjustment ring left (counter-clockwise) to reduce the torque. After setting up the torque, put torque cover back and fasten it tightly to avoid changing set-up accidentally. (as illustrated below)
5. Right/Left Indication: Turn right (clockwise) the switch (marked “R”) for tightening screws. Turn left (counter-clockwise) the switch (marked “L”) for loosening screws.

## 6. Two ways to operate:

**A. Push + Pull The Trigger to Start:** Set the bit aiming the screw. Push down the tool steadily and pull the trigger to activate the motor. When the required torque is reached, the motor will shut off automatically. Either releasing the trigger or take the tool away from the fixing will stop the motor. (Dual security design)

**B. Push to Start:** Press the trigger and push the “Locking” switch to the right to lock the trigger. Push down the tool steadily to activate the motor. The operation can be repeated without pulling trigger constantly. When the required torque is reached, the motor will shut off automatically.

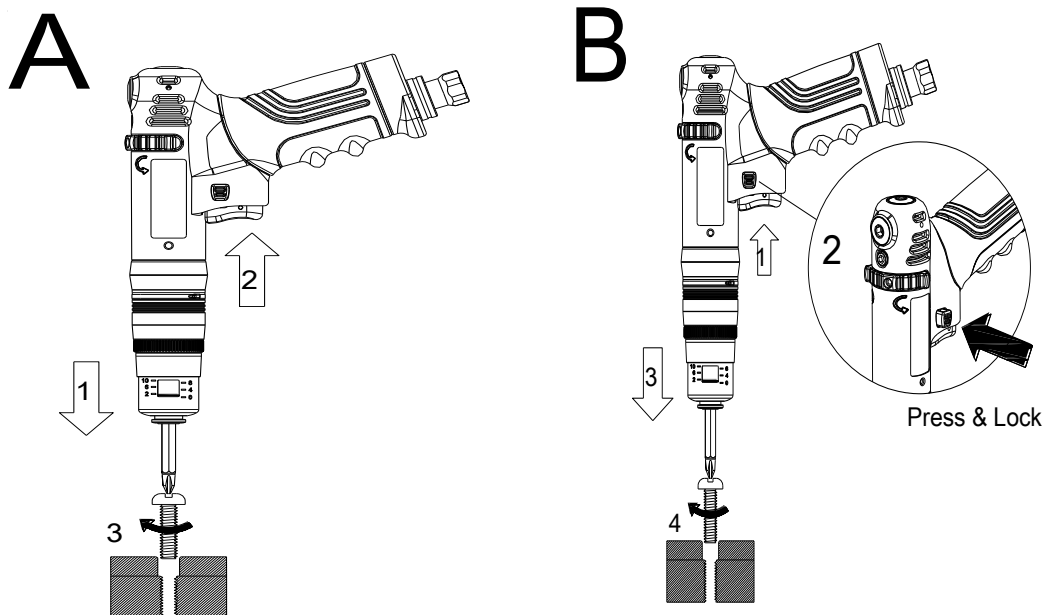

7. Suggestion: Correct / Re-set torques before operation on a daily basis.
8. If the tool is not to be used for a long time, re-set the torque to the lowest.

## Switch Operation of Three Way Air-inlet

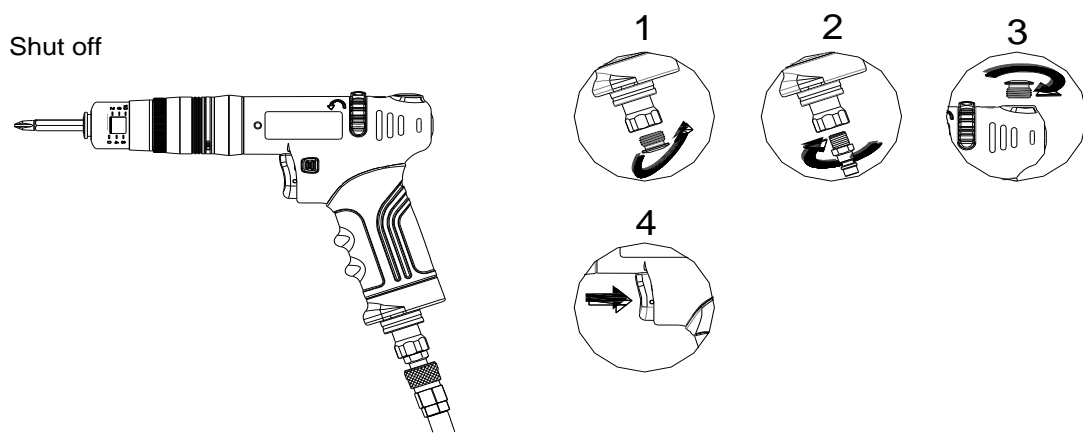
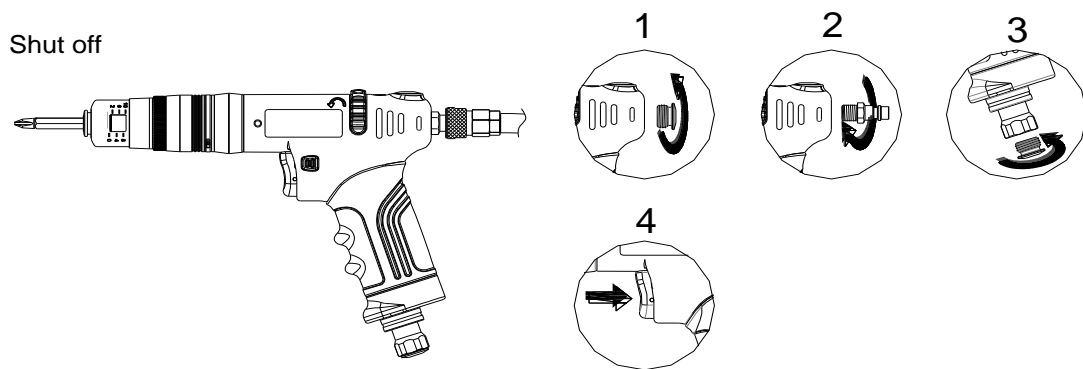
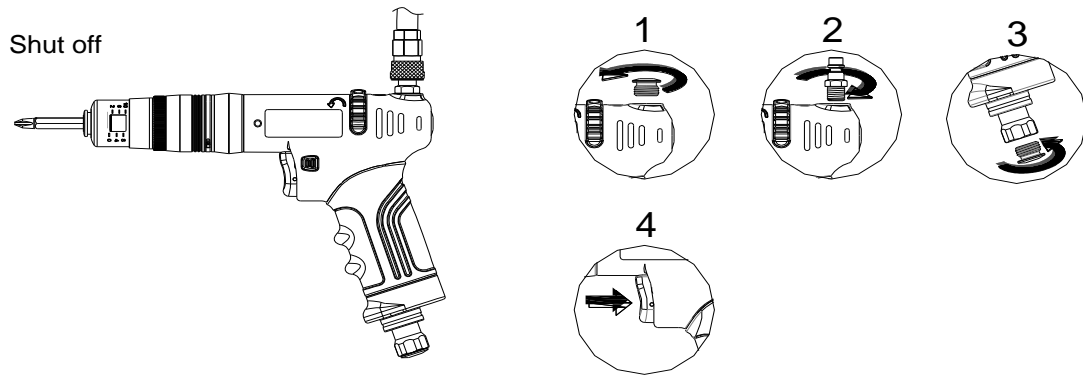

## Installation of Bit

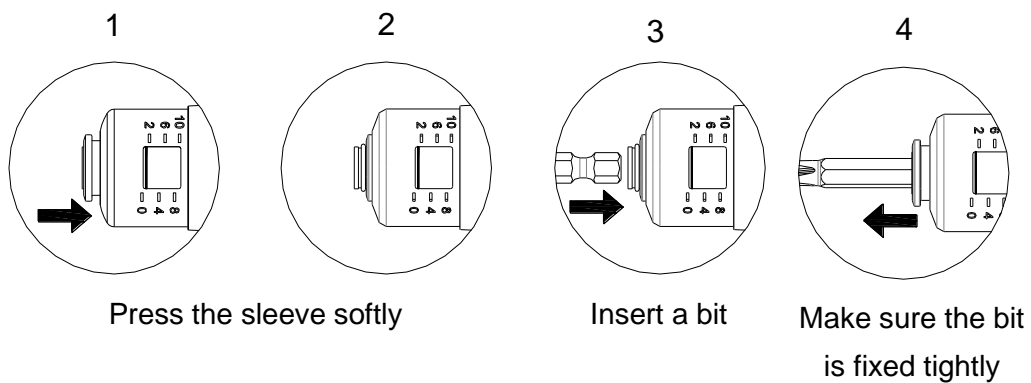

## Set-up of Torque

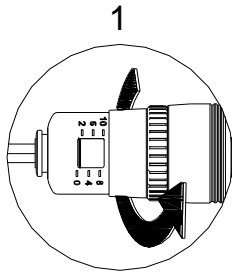

Release and remove the torque cover

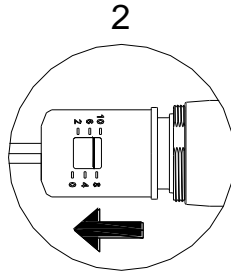

Insert torque adjustment ring to the tool

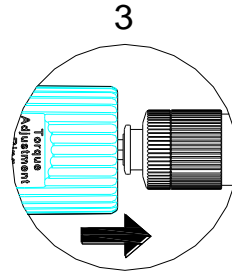

Turn counter clockwise to lower the torque

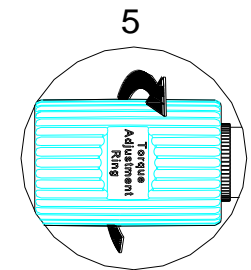
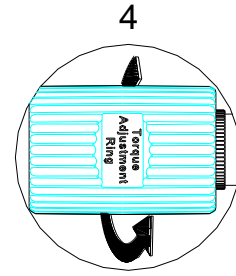

Turn clockwise to increase the torque

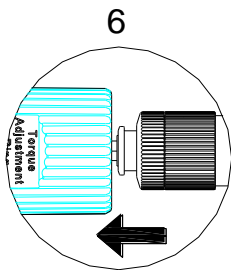

Take off the adjustment ring

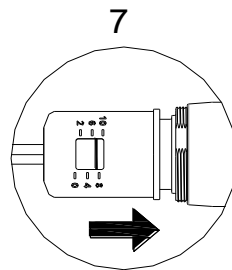

Put the torque cover back

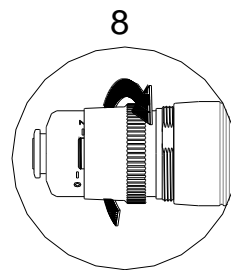

Fasten the rear housing tightly

## Operation of R/L Switch

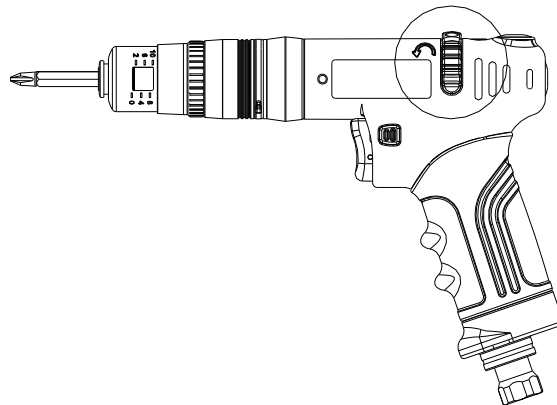

**R Indication** – turn right (clockwise)  
– fastening screw

**L Indication** – turn left (counter clockwise)  
– loosening screw

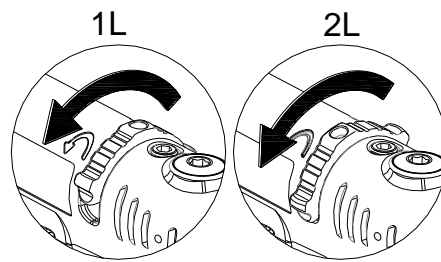
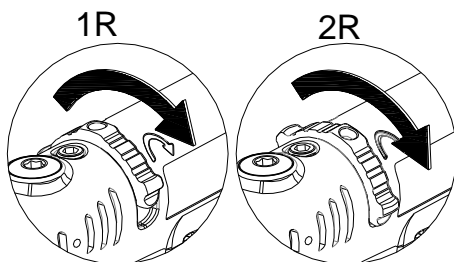

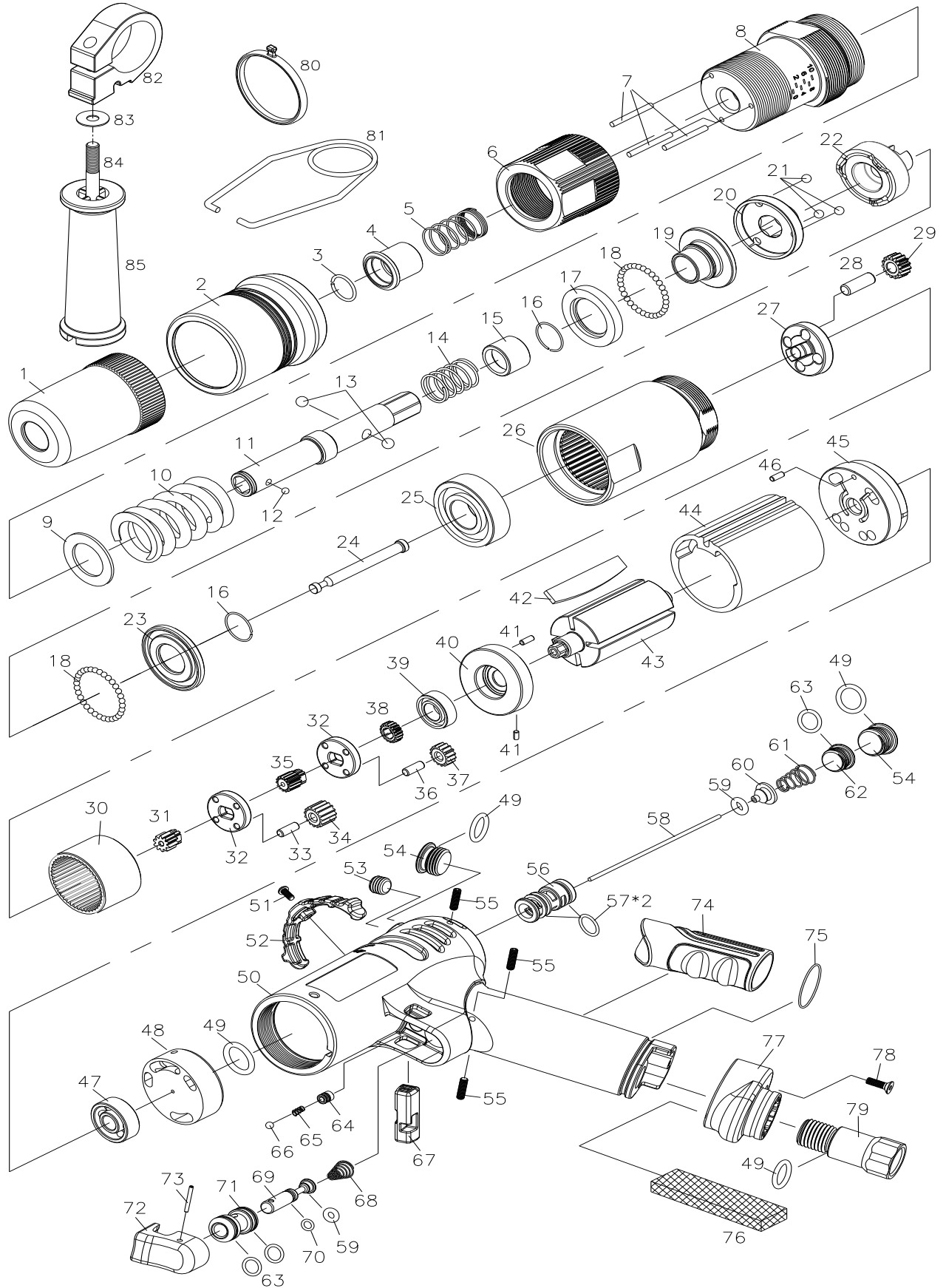
**UT8943 AUTO SHUT-OFF PISTOL SCREWDRIVER, 300rpm / 3.0~18Nm**

**UT8943 AUTO SHUT-OFF PISTOL SCREWDRIVER, 300rpm / 3.0~18Nm**

INDEX NO	PARTS NO.	DESCRIPTION	QTY/SET	INDEX NO	PARTS NO.	DESCRIPTION	QTY/SET
1	7165001PG-1	TORQUE COVER	1	43	7165040PS	ROTOR	1
2	7160070PG	HOUSING CAP	1	44	7160042PS	CYLINDER	1
3	7160002PS	C RING	1	45	7160043PS	END PLATE	1
4	7160003PS	BIT RETAINER SLEEVE	1	46	SPP0208	SPRING PIN	1
5	7160004PS	SPRING	1	47	B606ZZ-NMB	BALL BEARING	1
6	7160005A	TORQUE RING	1	48	7160048PG	VALVE	1
7	7140007PS	NEEDLE PIN	3	49	OR1898	O-RING	4
8	7165008PG	CLUTCH HOUSING	1	50	7160063PG-BK	MOTOR HOUSING	1
9	7160010A	WASHER	1	51	7160052PS	SCREW	1
10	7168011PG	TORQUE SPRING	1	52	7160051PG-RD	SWITCH	1
11	7160012PS	ANVIL	1	53	HEXM806	SCREW	1
12	7160013PS	STEEL BALL	1	54	7120067PG	SCREW CAP	2
13	7160014PS	STEEL BALL	2	55	HEXM308	SCREW	4
14	7160015PS	SPRING	1	56	7120069PG	VALVE BUSHING	1
15	7160016PS	SLIDE BASE	1	57	589058	O-RING	2
16	7160017PS	C RING	2	58	7165054PG	OPERATING ROD	1
17	7160018PS	BALL RACE	1	59	OR0302	O-RING	2
18	7160019PS	STEEL BALL	60	60	7160056PS	VALVE PLATE	1
19	7160020PS	END CLUTCH	1	61	7160057PS	SPRING	1
20	7160021PS-3P	CENTER CLUTCH	1	62	7120068PG	SCREW	1
21	STB3175	STEEL BALL	3	63	OR0612	O-RING	3
22	7160023PS-3P	REAR CLUTCH	1	64	7120076PG	PLUG	1
23	7160024PS	RETAINER	1	65	611239-1	SPRING	1
24	7160025PS	PILOT PIN	1	66	SB0003-1	STEEL BALL	1
25	B6001Z-TPI	BALL BEARING	1	67	7120075PG	TRIGGER LOCKING	1
26	7165027PG	FRONT HOUSING	1	68	7120073PG	SPRING	1
27	7165029PG	SPACER	1	69	7120065PG	TRIGGER PIN	1
28	7160030PS	PIN	4	70	OR0312	O-RING	1
29	7165078PG	PLANETARY GEAR	4	71	7120066PG	BUSHING	1
30	7165036PG	INTERNAL GEAR	1	72	7120074PG	TRIGGER	1
31	7165077PG	SUN GEAR	1	73	SPP0214	SPRING PIN	1
32	7150033PS	GEAR CAGE	2	74	7120072PG	GRIP	1
33	7150030PS	PIN	4	75	OR2402	O-RING	1
34	7150031PS	PLANETARY GEAR	4	76	ZZ389507	SILENCER	1
35	7150032PS	SUN GEAR	1	77	7120071PG	EXHAUST DEFLECTOR	1
36	7120030PS	PIN	4	78	861432-3	SCREW	1
37	7120031PS	PLANETARY GEAR	4	79	7120062PG	AIR INLET	1
38	7165032PG	SUN GEAR	1	80	7160080PS	DISTINGUISHABLE RING (4)	1
39	L-1680HH	BALL BEARING	1	81	CP1HP60	SUSPENSION RING	1
40	7165039PG	FRONT PLATE	1	82	389847	ARM CASE	1
41	589040	SPRING PIN	2	83&84	389849/389848-1	WASHER & SCREW	1
42	7160041PS	BLADE	4	85	389848	ARM	1

Division of Florida Pneumatic Mfg Corp.,  
851 Jupiter Park Lane,  
Jupiter, FL 33458, USA.  
Ph: (1) 561 744 9500  
Fax: (1) 561 575 5574

## EC/UKCA DECLARATION OF CONFORMITY

We **FLORIDA PNEUMATIC MFG CORP, 851 JUPITER PARK LANE, JUPITER, FL 33458, USA**

Declare under our sole responsibility that the machine falls within the provisions of the directive:

Machine Type:            UT8943 Air Auto Shut-Off Screwdriver

Technical Data:

<b>Chuck Size :</b>	<u>1/4" HEX.QC</u>	<b>Free Speed:</b>	<u>300 rpm</u>
<b>Weight:</b>	<u>1.45 kg (3.19 lbs)</u>	<b>Length:</b>	<u>231 mm (9.10")</u>
<b>Recommended Hose Size:</b>	<u>10m (3/8")</u>	<b>Working Air Pressure:</b>	<u>6.3 bar (90 PSI)</u>
<b>Noise:</b> (sound pressure level)	<u>72 dB(A)</u>	<b>Vibration:</b>	<u>1.81 Metres / Sec <sup>2</sup></u>
<b>Spindle size:</b>	<u>N/A</u>	<b>Serial No:</b>	_____

To which this declaration relates, is in conformity with the requirements of : The Machinery Directive 2006/42/EC, General Safety ISO 12100:2010, Specific Safety-Impact Wrenches: ISO 11148-6: 2012, Specific Vibration- ISO 28927, Noise: ISO 15744:2008

Name and position of issuer: **Tony Le Neveu: V P Engineering & Development**

