



# Universal Tool

## Operator Instructions

Includes - Foreseen Use, Work Stations, Putting Into Service, Operating, Dismantling, Assembly and Safety Rules

Manufacturer/Supplier

**Universal Air Tool Company Limited**  
**Unit 8**  
**Lane End Industrial Park**  
**High Wycombe**  
**Bucks**  
**HP14 3BY**

Tel No **(01494) 883300** Fax No **(01494) 883237**

Product Nett Weight

**15.9** lbs

**7.2** Kg

Recommended Use Of  
Balancer Or Support

**Yes**

Air Pressure

Recommended Working **6.3** bar **90** PSI

Recommended Minimum **n/a** bar **n/a** PSI

Maximum **7.0** bar **100** PSI

Personal Safety Equipment

Use - Safety Glasses **Yes**

Use - Safety Gloves

Use - Safety Boots

Use - Breathing Masks

Use - Ear Protectors **Yes**

## Important

**Read these instructions carefully before installing, operating, servicing or repairing this tool. Keep these instructions in a safe accessible place.**

Product Type

**1" Lightweight Impact Wrench**

RPM  
**6,000**  
Cycles Per Min



Model No/Nos

**UT8468 - Straight Handle**

Serial No

Recommended Hose Bore  
Size - Minimum

**1/2** Ins **13** M/M

Recommended Max.  
Hose Length

**30** Ft **10** M

Noise Level **Sound Pressure Level 86.0 dB(A)**

Test Method **Tested in accordance with Pneurop test code PN8NTC 1**

Vibration Level **6.55 Metres / Sec<sup>2</sup>**

Test Method **Tested in accordance with ISO standard 8662**

## Foreseen Use Of Tool

The impact wrench is designed for the tightening and loosening of threaded fasteners within the range as specified by the manufacturer. It should only be used in conjunction with suitable impact type 1" square female drive nut running sockets. Only use sockets which are of the impact type.

It is allowed to use suitable extension bars, universal joints and socket adaptors between the square output drive of the impact wrench and the square female drive of the socket.

Do not use the tool for any other purpose than that specified without consulting the manufacturer or the manufacturer's authorised supplier. To do so may be dangerous.

Never use an impact wrench as a hammer to dislodge or straighten cross threaded fasteners. Never attempt to modify the tool for other uses and never modify the tool for even its recommended use as a nutrunner.

## Work Stations

The tool should only be used as a handheld hand operated tool. It is always recommended that the tool is used when standing on the solid floor. It can be in other positions but before any such use, the operator must be in a secure position having a firm grip and footing and be aware that when loosening fasteners the tool can move quite quickly away from the fastener being undone. An allowance must always be made for this rearward movement so as to avoid the possibility of hand/arm/body entrapment.

## Putting Into Service

### Air Supply

Use a clean lubricated air supply that will give a measured air pressure at the tool of 90 p.s.i./6.3 bar when the tool is running with the trigger fully depressed and the air regulator in its maximum opening flow position. Use recommended hose size and length. It is recommended that the tool is connected to the air supply as shown in figure 1. Do not connect a quick connect coupling directly to the tool but use a whip or leader hose of approximately 12 inches length. Do not connect the tool to the air line system without incorporating an easy to reach and operate air shut off valve. The air supply should be lubricated. It is strongly recommended that an air filter, regulator, lubricator (FRL) is used as shown in Figure 1 as this will supply clean, lubricated air at the correct pressure to the tool. Details of such equipment can be obtained from your supplier. If such equipment is not used then the tool should be lubricated by shutting off the air supply to the tool, depressurising the line by pressing the trigger on the tool. Disconnect the air line and pour into the intake bushing a teaspoonful (5ml) of a suitable pneumatic motor lubricating oil preferably incorporating a rust inhibitor. Reconnect

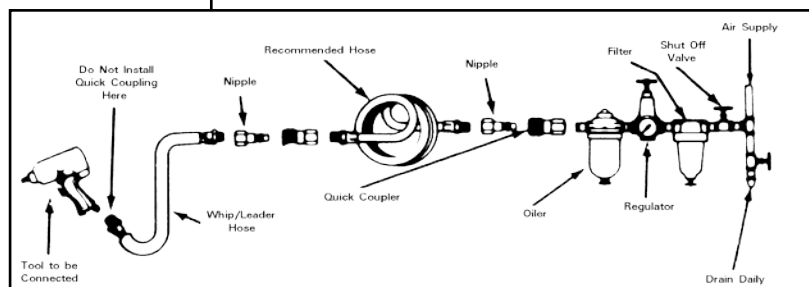

tool to air supply and run tool slowly for a few seconds to allow air to circulate the oil. If tool is used frequently lubricate on daily basis and if tool starts to slow or lose power. When lubricating, also ensure that screen is clean.

It is recommended that the air pressure at the tool whilst the tool is running is 90 p.s.i./6.3 bar. The tool can run at lower and higher pressures with the maximum permitted working air pressure of 100 p.s.i./7.0 bar. For a lower air pressure the tool will give a lower output for a given setting of the air regulator set for 90 psi operation and an increased output for higher pressures. Hence it is possible that changes in supply pressure can give situations where the fastener is under or over tightened. For changes in pressure, the regulator position and application should be reassessed.

It is recommended that joint tightness of the threaded fastener assembly be checked with suitable measuring equipment.

---

## Operating

The output of the impact wrench in prime working condition is governed by mainly three factors

- a) the input air pressure
- b) the time the impact wrench is operated on the joint. Normal time for joints of average tension requirement 3 to 5 seconds
- c) the setting of the air regulator for a given joint at a given pressure operated for a given time.

It is strongly recommended that an external pressure regulator ideally as part of a filter/regulator/lubricator (FRL) is used to control air inlet pressure so that the pressure can be set to help control the tension required to be applied to the threaded fastener joint.

There is no consistent reliable torque adjustment on an impact wrench of this type. However, the air regulator can be used to adjust torque to the approximate tightness of a known threaded joint. To set the tool to the desired torque, select a nut or screw of known tightness of the same size, thread pitch and thread condition as those on the job. Turn air regulator to low position, apply wrench to nut and gradually increase power (turn regulator to admit more air) until nut moves slightly in the direction it was originally set. The tool is now set to duplicate that tightness, note regulator setting for future use. When tightening nuts not requiring critical torque values, run nut up flush and then tighten an additional one-quarter to one-half turn (slight additional turning is necessary if gaskets are being clamped). For additional power needed on disassembly work, turn regulator to its fully open position. This impact wrench is rated a 1" bolt size. Rating must be down graded for spring U bolts, tie bolts, long cap screws, double depth nuts, badly rusted conditions and spring fasteners as they absorb much of the impact power. When possible, clamp or wedge the bolt to prevent springback.

Soak rusted nuts in penetrating oil and break rust seal before removing with impact wrench. If nut does not start to move in three to five seconds use a larger size impact wrench. Do not use impact wrench beyond rated capacity as this will drastically reduce tool life.

Note: Actual torque on a fastener is directly related to joint hardness, tool speed, condition of socket and the time the tool is allowed to impact.

Use the simplest possible tool-to-socket hook up. Every connection absorbs energy and reduces power.

---

## Tool Maintenance

It shall be the tool owner's and/or employer's responsibility to assure that tools are maintained in a safe operating condition. Tool maintenance and repair shall be performed by authorised, trained, competent personnel. Tools shall be disconnected from their compressed air supply before repairs are attempted. Repairs shall be consistent with the manufacturer's recommended procedures. Tool, hoses and fittings shall be replaced if unsuitable for safe operation. It shall be the tool owner's and/or employer's responsibility to keep required rating markings and warnings on the tool in legible condition.

## Safety Rules When Using an Impact Wrench

1) Read all the instructions before using this tool. All operators must be fully trained in its use and aware of these safety rules. All service and repair must be carried out by trained personnel.

2) The socket used must be of the correct drive size and the "impact" type. Never use sockets other than impact type.

3) Do not use sockets with excessive wear to the input and output drives. Check that the square on any other type of drive or the impact wrench is not cracked or excessively worn before fitting or changing socket, extension, etc. Make sure that the socket is firmly fixed to the tool.

4) Always ensure that a stable position or footing is adopted before using the tool.

5) Ensure that the tool has been correctly set up on a test joint. Incorrect set up could cause joint breakage with sudden and unexpected movement of the tool.

6) Use only correct spare parts for repair.

7) Always ensure that the reverse valve is in the correct position before operating the tool. Do not run the tool unless the socket is first located on the joint.

8) Check hose and fittings regularly for wear. Use quick connect couplings only as recommended. See "Putting into Service". Do not carry the tool by the hose and ensure that the hand is away from the on/off valve when carrying.

9) Do not attempt to hold or guide the socket by hand when the tool is running.

10) Do not exceed maximum recommended air pressure.

11) Use safety equipment as recommended.

12) The tool is not electrically insulated. Do not use where there is a possibility of coming into contact with live electricity.

13) Preferably shut off the air supply before changing sockets or at least ensure that the hands are well clear of the operating trigger.

14) Take care against entanglement of moving parts of the tool with clothing, ties, hair, cleaning rags, etc.

15) When loosening fasteners first ensure that there is sufficient clearance behind the tool to avoid hand entrapment. The tool will move away from the threaded joint as the nut/bolt etc. is loosened and rides up the thread moving the tool with it.

16) Only use extensions, adaptors and universal joints suitable for use with impact wrenches.

17) If the tool appears to malfunction remove from use immediately and arrange for service and repair.

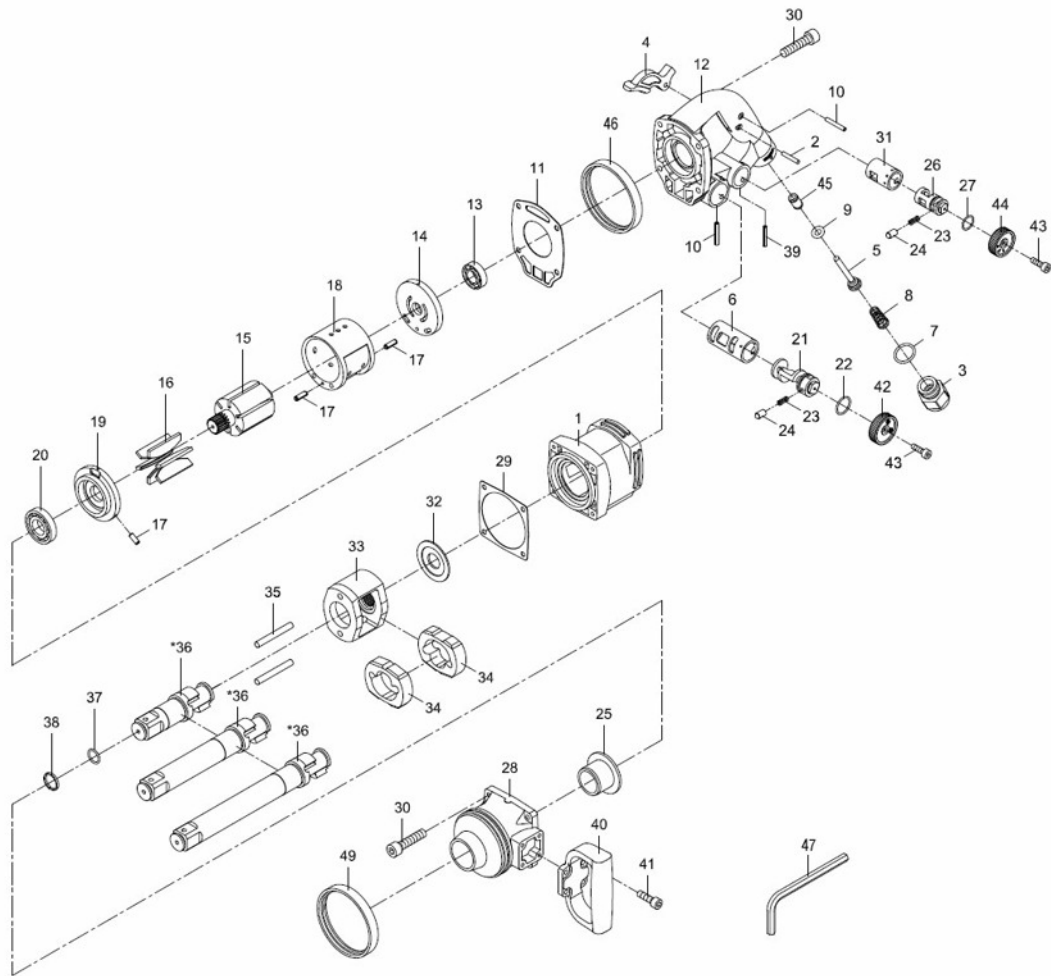

Ref No	Part No	Description
1	8468-01	Motor Housing
2	8468-02	Pin
3	8468-03	Air Inlet
4	8468-04	Trigger
5	8468-05	Valve Stem
6	8468-06	Valve Bushing
7	8468-07	O-Ring (2)
8	8468-08	Valve Spring
9	8468-09	O-Ring
10	8468-10	Spring Pin (2)
11	8468-11	Gasket
12	8468-12	Back Handle
13	8468-13	Ball Bearing
14	8468-14	Rear End Plate
15	8468-15	Rotor
16	8468-16	Rotor Blade (6)
17	8468-17	Spring Pin (3)
18	8468-18	Cylinder
19	8468-19	Front End Plate
20	8468-20	Ball Bearing
21	8468-21	Reverse Valve
22	8468-22	O-Ring
23	8468-23	Spring
24	8468-24	Pin

Ref No	Part No	Description
25	8468-25	Anvil Bushing
26	8468-26	Regulator Valve
27	8468-27	O-Ring
28	8468-28	Hammer Case
29	8468-29	Gasket
30	8468-30	Screw (8)
31	8468-31	Valve Bushing
32	8468-32	Washer
33	8468-33	Hammer Cage
34	8468-34	Hammer (2)
35	8468-35	Pin (2)
36	8468-36	8" Anvil
37	8468-37	O-Ring
38	8468-38	Retainer Ring
39	8468-39	Spring Pin
40	8468-40	Dead Handle
41	8468-41	Screw (4)
42	8468-42	Regulator Knob
43	8468-43	Screw (2)
44	8468-44	Regulator Knob
45	8468-45	Bushing
46	8468-46	Rubber Ring
47	8468-47	Hex. Key Wrench

**Declaration of Conformity**  
**Universal Air Tool Company Limited**  
**Unit 8, Lane End Industrial Park, High Wycombe, Bucks, HP14 3BY, England**

declare under our sole responsibility that the product

**Model UT8468 1" Lightweight Impact Wrench, Serial Number**  
to which this declaration relates is in conformity with the following standard(s) or other normative document(s)  
**EN792 (Draft), EN292 Parts 1 & 2, ISO 8662 Parts 1, 2 & 14, Pneurop PN8NTC1**  
following the provisions of **Directive 2006/42/EC**

**Lane End**

ARTHUR PATERSON



Place of issue

For and on behalf of the company

**Accessories**

**Notes**

**Distributor**