



Universal Tool

Operator Instructions

Includes - Foreseen Use, Work Stations, Putting Into Service, Operating, Dismantling, Assembly and Safety Rules

Manufacturer/Supplier

Universal Air Tool Company Limited
Unit 8
Lane End Industrial Park
High Wycombe
Bucks
HP14 3BY

Tel No **(01494) 883300** Fax No **(01494) 883237**

Product Nett Weight 1.7 lbs 0.8 Kg	Recommended Use Of Balancer Or Support No	Recommended Hose Bore Size - Minimum 3/8 Ins 10 M/M	Recommended Max. Hose Length 30 Ft 10 M
--	--	---	---

Air Pressure		Noise Level Sound Pressure Level 86.0 dB(A)	
Recommended Working	6.3 bar 90 PSI	Test Method Tested in accordance with Pneurop test code PN8NTC 1	
Recommended Minimum	n/a bar n/a PSI		
Maximum	7.0 bar 100 PSI		

Personal Safety Equipment	Vibration Level Less than 2.5 Metres / Sec²
Use - Safety Glasses Yes	Test Method Tested in accordance with ISO standard 8662
Use - Safety Gloves Yes	
Use - Safety Boots	
Use - Breathing Masks Yes	
Use - Ear Protectors Yes	

Foreseen Use Of The Tool

This die grinder is primarily designed for use with bonded abrasive mounted point grinding wheels. It may also be used with steel rotary files and carbide burrs provided their speed rating matches the speed of the grinder.

This tool should not be fitted with cutting off wheels, saw blades, drill bits, etc. If there is any doubt about the correct use of this product contact your supplier for advice.

Also make sure that the shank size of the attachment to be driven matches with the collet size fitted in the grinder and that the maximum allowed running speed of the attachment exceeds that marked on the grinder.

There are special rules governing the use of bonded abrasive mounted point grinding wheels - for details see section "Operating".

Work Stations

The tool should only be used as a handheld hand operated tool. It is always recommended that the tool is used when standing on the solid floor. It can be used in other positions but before any such use, the operator must be in a secure position having a firm grip and footing and be aware of the extra safety precautions that must be observed when using Grinding Machines.

Important

Read these instructions carefully before installing, operating, servicing or repairing this tool. Keep these instructions in a safe accessible place.

Product Type Die Grinder	RPM 20,000 Cycles Per Min	
------------------------------------	--	--

Model No/Nos UT5721	Serial No
-------------------------------	-----------

Noise Level **Sound Pressure Level 86.0 dB(A)**

Test Method **Tested in accordance with Pneurop test code PN8NTC 1**

Vibration Level **Less than 2.5 Metres / Sec²**

Test Method **Tested in accordance with ISO standard 8662**

Putting Into Service

Air Supply

Use a clean lubricated air supply that will give a measured air pressure at the tool of 90 p.s.i./6.3 bar when the tool is running with the lever/trigger fully depressed. Use recommended hose size and length. It is recommended that the tool is connected to the air supply as shown in figure 1. Do not connect the tool to the air line system without incorporating an easy to reach and operate air shut off valve. The air supply should be lubricated. It is strongly recommended that an air filter, regulator, lubricator (FRL) is used as shown in Figure 1 as this will supply clean, lubricated air at the correct pressure to the tool. Details of such equipment can be obtained from your supplier. If such equipment is not used then the tool should be lubricated by shutting off the air supply to the tool, depressurising the line by pressing the lever/trigger on the tool. Disconnect the air line and pour into the intake bushing a teaspoonful (5ml) of a suitable pneumatic motor lubricating oil preferably incorporating a rust inhibitor. Reconnect tool to air supply and run tool slowly for a few seconds to allow air to circulate the oil. If tool is used frequently lubricate on

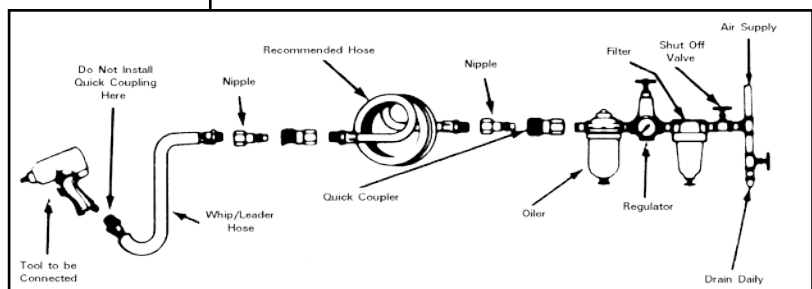

daily basis and if tool starts to slow or lose power.

It is recommended that the air pressure at the tool whilst the tool is running is 90 p.s.i./6.3 bar. The tool can run at lower and higher pressures with the maximum permitted working air pressure of 100 p.s.i./7.0 bar.

Operating

Select a suitable mounted point that has a free running speed higher than the maximum running speed marked on the tool. Make sure that the diameter of the shank exactly matches the diameter of the collet mounted in the grinder. There are four standard sizes of collet available for use with this grinder, i.e.

- 1) - 1/4" dia (0.250ins)(6.35mm)
- 2) - 6mm (0.236ins)
- 3) - 1/8" (0.125ins)(3.175mm)
- 4) - 3mm (0.118ins)

* available to order 2mm, 2.5mm, 3.5mm and 5mm diameter collets
Never try to force a 1/4" diameter shank into a 6mm collet or a 1/8" diameter shank into a 3mm collet. Never try to close a 1/4" diameter collet to secure a 6mm shank or a 1/8" diameter collet to secure a 3mm diameter shank. Always match correctly the shank size to the collet size. If uncertain, have parts measured by a competent person. Push the shank as far as possible into the collet and tighten the collet nut using the spanners provided on the collet nut and output spindle. The shank of the mounted point may be pulled forward from the maximum insertion length but always ensure a minimum gripping length of not less than 10mm - See Figure 2.

Be aware that the allowed running speed of the mounted point is lowered because of an increase in the length of the shank between the end of the collet and the body of the mounted point. This distance is shown in Diagram 2 as "LO" and is called the overhang. The information with respect to mounted point size, permissible running speed and reduction in running speed due to an increase in overhang is available from the supplier of the mounted point.

If the increase in overhang for access reasons takes the permissible running speed of the mounted point below the free running speed of the grinder select a smaller diameter mounted point.

The fitting of the mounted point should be done by a trained operator. When first starting the grinder with a new wheel fitted, the grinder should not be near other persons and be held in a protected area, i.e. under a bench and run for a few seconds. This will protect personnel from possible effects of damage to the mounted point before it was fitted to the grinder i.e. wheel breakage.

Always use eye protection and wear protective gloves if there are sharp edges in the work area. The tool and the grinding process can create a noise level such that the use of ear protectors is advised.

If the grinding process creates a dust then use a suitable breathing mask.

Check that the material being worked will not cause harmful dust or fumes. If this is so then special breathing masks may be required.

If the grinder vibrates when first fitting a mounted point or during operation, remove from service immediately and correct fault before continuing to use.

Do not apply excessive pressure as this will reduce the cutting efficiency and can bend the shank of the mounted point causing vibration and the possibility of breakage. Apply light loads to allow the wheel to cut.

Handle the grinder with care. If the grinder is dropped, carefully check the mounted point for damage, i.e. cracks, chipping and start for the first time as for fitting a new wheel i.e. under a bench.

Never exceed the maximum air pressure. If there is this possibility always use this grinder with a pressure reducing valve fitted in the supply line. Your supplier will advise of suitable equipment.

This grinder is fitted with a speed regulator and the speed may be reduced by rotating air regulator(4) with a suitable screwdriver. When making speed checks always rotate the air regulator to the position to give the highest maximum speed.

Tool Maintenance

It shall be the tool owner's and/or employer's responsibility to assure that tools are maintained in a safe operating condition. Tool maintenance and repair shall be performed by authorised, trained, competent personnel. Tools shall be disconnected from their compressed air supply before repairs are attempted. Repairs shall be consistent with the manufacturer's recommended procedures. Tool, hoses and fittings shall be replaced if unsuitable for safe operation. It shall be the tool owner's and/or employer's responsibility to keep required rating markings and warnings on the tool in legible condition.

Safety Rules When Using A Die Grinder

- 1) Read all the instructions before using this tool. All operators must be fully trained in its use and aware of these safety rules.
- 2) Always select suitable abrasive to use with this tool - see Operating Instructions.
- 3) Always shut off the air supply to the grinder and depress the lever to exhaust air from the feed hose before fitting, adjusting or removing the mounted point.
- 4) Always adopt a firm footing and/or position before using the grinder.
- 5) Use only correct spare parts.
- 6) Check hose and fittings regularly for wear. Do not carry the tool by its hose.
- 7) Do not remove and never tie down the safety lever.
- 8) Never exceed the maximum air pressure and check the free running speed frequently. Have air regulator fully open when making speed checks.
- 9) Use safety equipment as recommended.
- 10) Take care against entanglement of moving parts of the tool with clothing, ties, hair, cleaning rags, etc.
- 11) Use only compressed air at the recommended pressure.
- 12) Do not attempt to fit any other attachment than those recommended - see "Foreseen Use of Tool".
- 13) If the tool appears to malfunction, remove from use immediately, and arrange for service and repair.

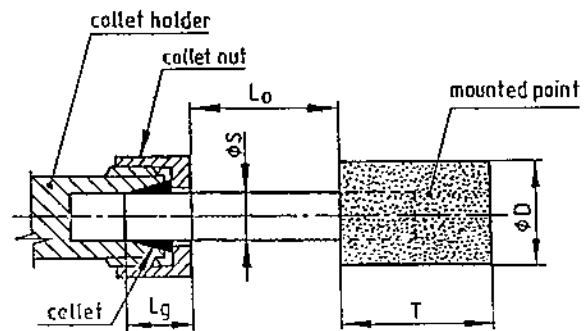
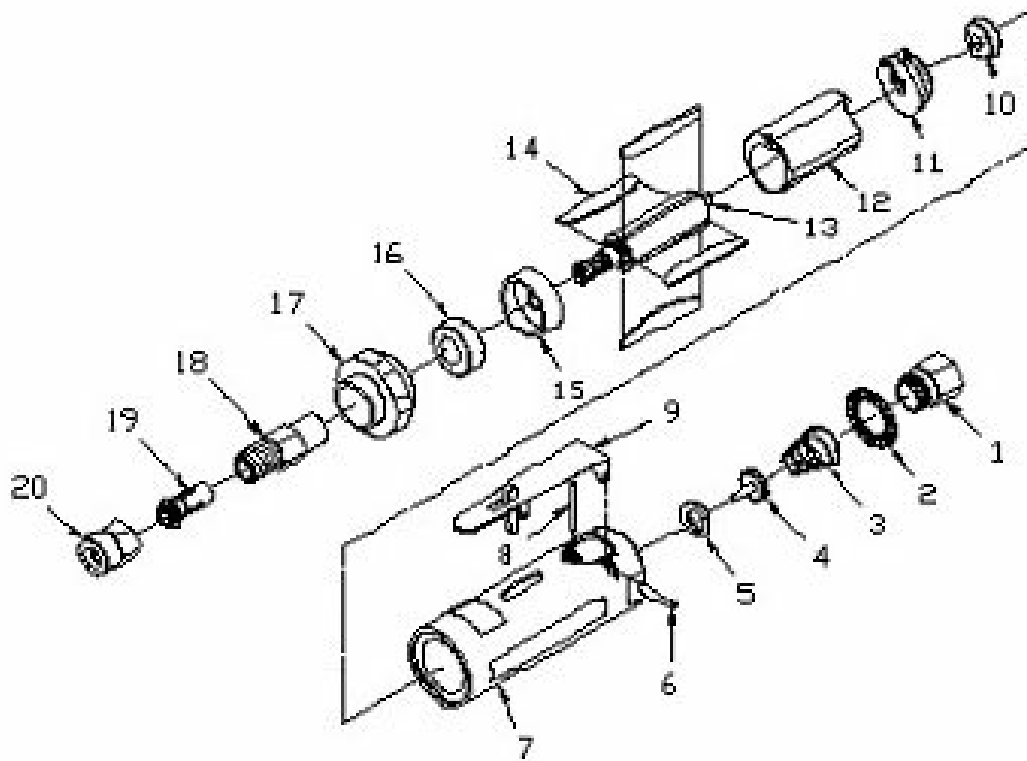

Figure 2. Gripping length of collet and chuck



Ref No	Part No	Description
1	5721-01	Hose Adaptor
2	5721-02	Muffler Disc
3	5721-03	Valve Spring
4	5721-04	Tip Valve
5	5721-05	Washer
6	5721-06	Lever Spring Pin
7	5721-07	Handle Assembly
8	5721-08	Valve Pin
9	5721-09	Lever Assembly
10	5721-10	Rear Bearing
11	5721-11	Rear End Plate
12	5721-12	Cage
13	5721-13	Rotor
14	5721-14	Rotor Blade (4)
15	5721-15	Front End Plate
16	5721-16	Front Bearing
17	5721-17	Lock Nut
18	5721-18	Collet Body
19	5721-19	Collet Insert
20	5721-20	Collet Nut

Declaration of Conformity
Universal Air Tool Company Limited
Unit 8, Lane End Industrial Park, High Wycombe, Bucks, HP14 3BY, England

declare under our sole responsibility that the product

Model UT5721 Die Grinder, Serial Number

to which this declaration relates is in conformity with the following standard(s) or other normative document(s)

EN792 (Draft), EN292 Parts 1 & 2, ISO 8662 Parts 1, 2 & 14, Pneurop PN8NTC1

following the provisions of **Directive 2006/42/EC**

Lane End

ARTHUR PATERSON



Place of issue

For and on behalf of the company

Accessories

Notes

Distributor

© Copyright of Universal Air Tool Company Limited, established in the United Kingdom, 1994

This document may not be copied wholly or in part by anyone without the consent of the Directors of Universal Air Tool Company Limited