

# AIR CAULKING GUN

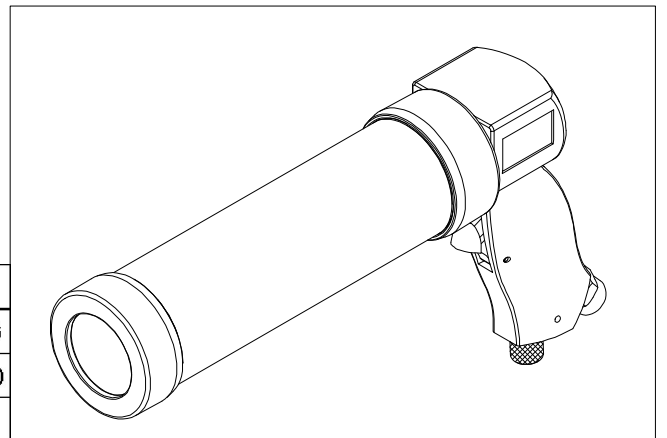
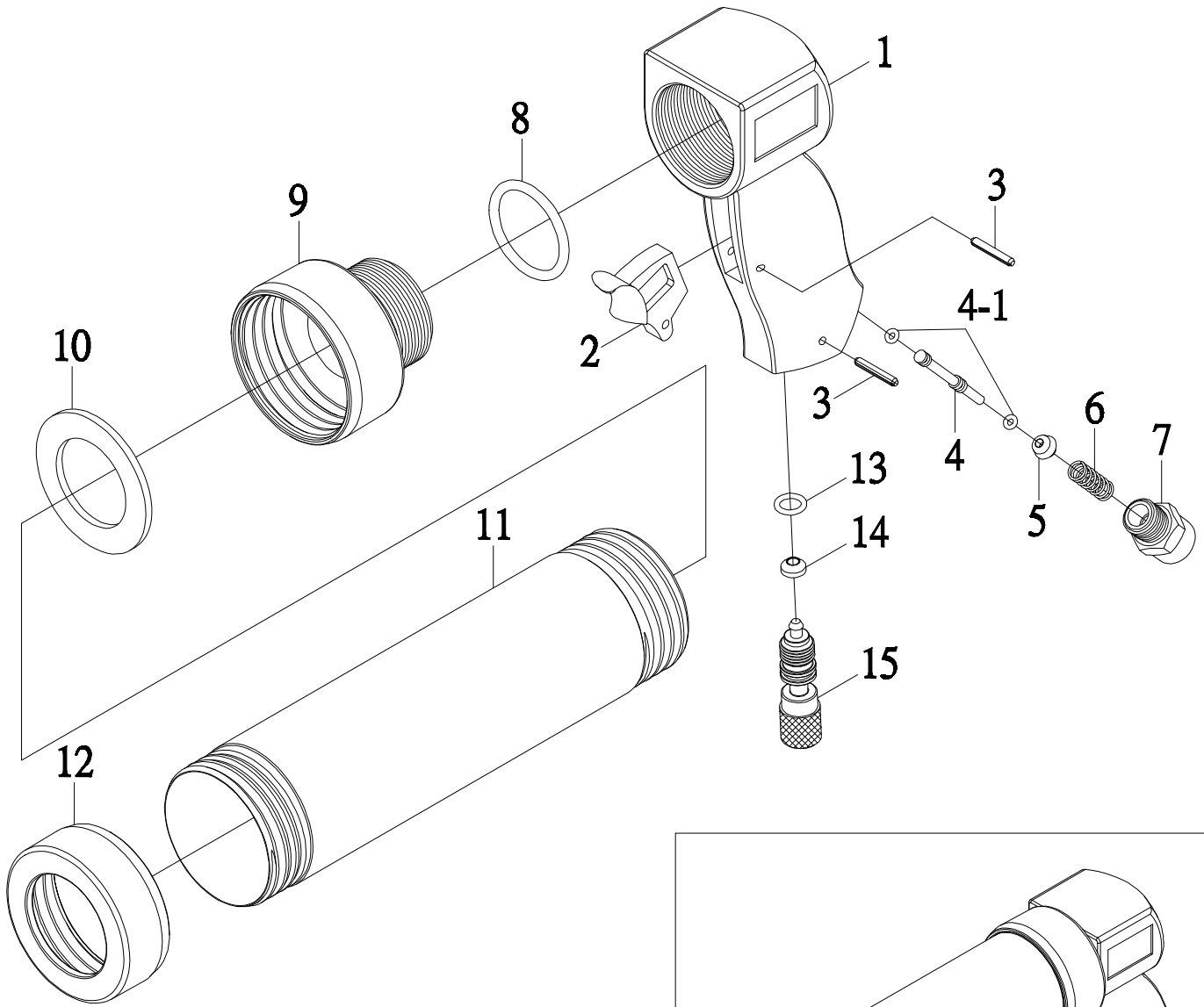

SPECIFICATION:	
*OPERATION-----50-70 PSI	*WEIGHT-----2 KG
*AIR CONS-----4 CFM	*AIR INLET-----1/4"PT(NPT)
*HOSE SIZE-----3/8"ID	

REF. NO.	PART NO.	DESCRIPTION	Q'TY	REF. NO.	PART NO.	DESCRIPTION	Q'TY
1	29901	HANDLE	1	8	29908	"O" RING (d31.7×W3.5) (P32)	1
2	29902	TRIGGER	1	9	29909	ADAPTOR	1
3	29903	SPRING PIN (∅3×20L)	2	10	29910	SEAL (d35×D55×W3)	1
4	29904	VALVE STEM	1	11	29911	CYLINDER	1
4-1	29904-1	"O" RING (d2.5×W1.5)	2	12	29912	END CAP	1
5	29905	VALVE BALL	1	13	29913	"O" RING (d7.8×W1.9) (P8)	1
6	29906	SPRING	1	14	29914	STEEL BALL SEAT	1
7	29907	INLET BUSHING	1	15	29915	REGULATOR	1